

# Augmented Finite State Machine

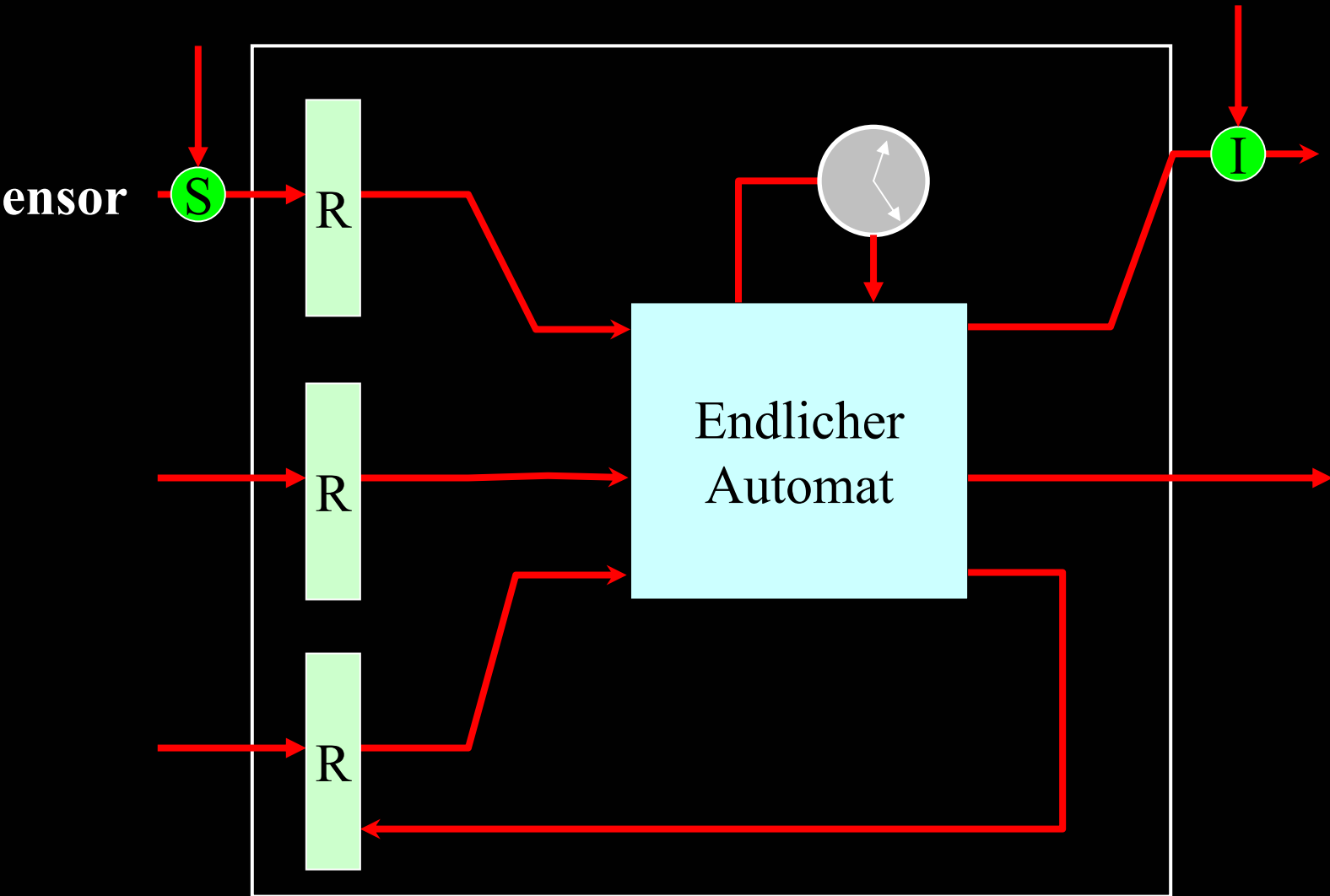

# Walking with six legs

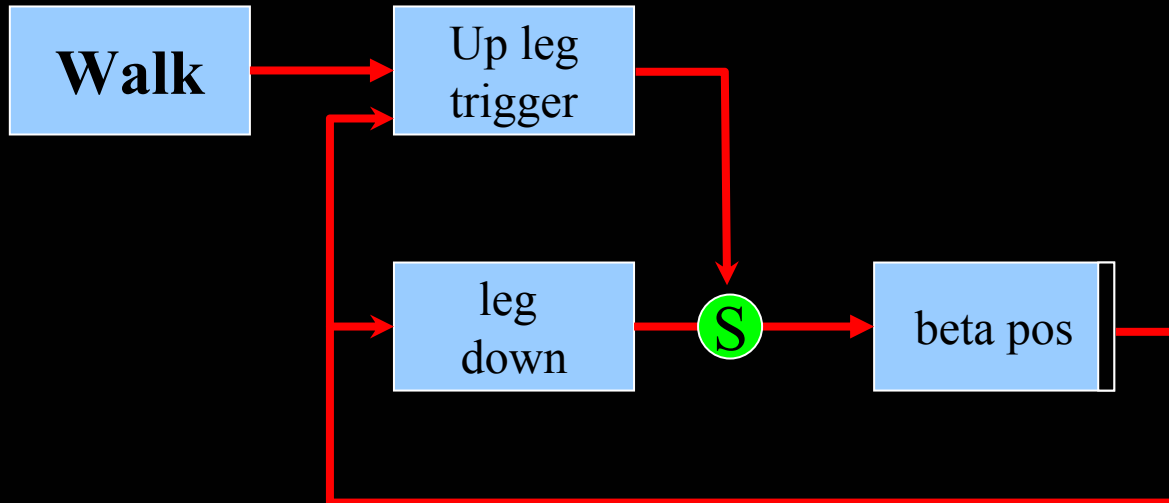
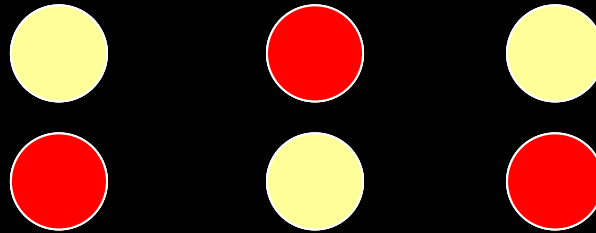

# Equilibrium of the legs

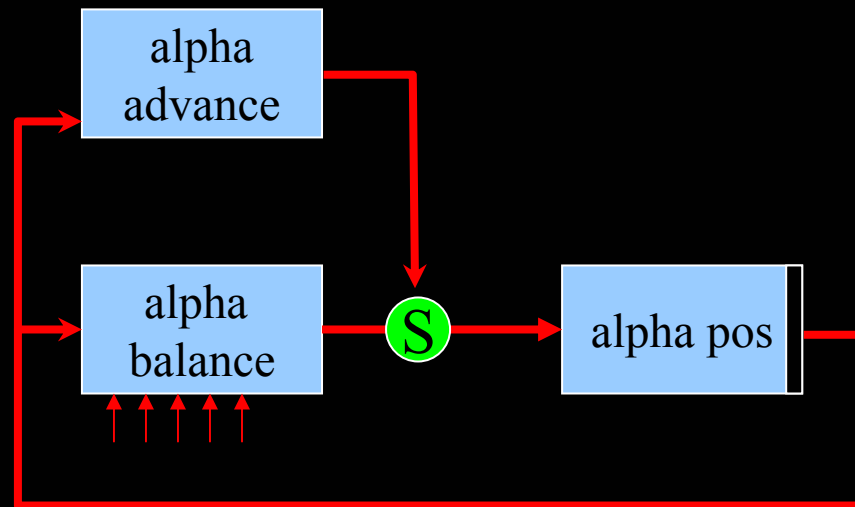

**Alpha balance tries to make  
the sum of the alpha angles zero**

# Walking

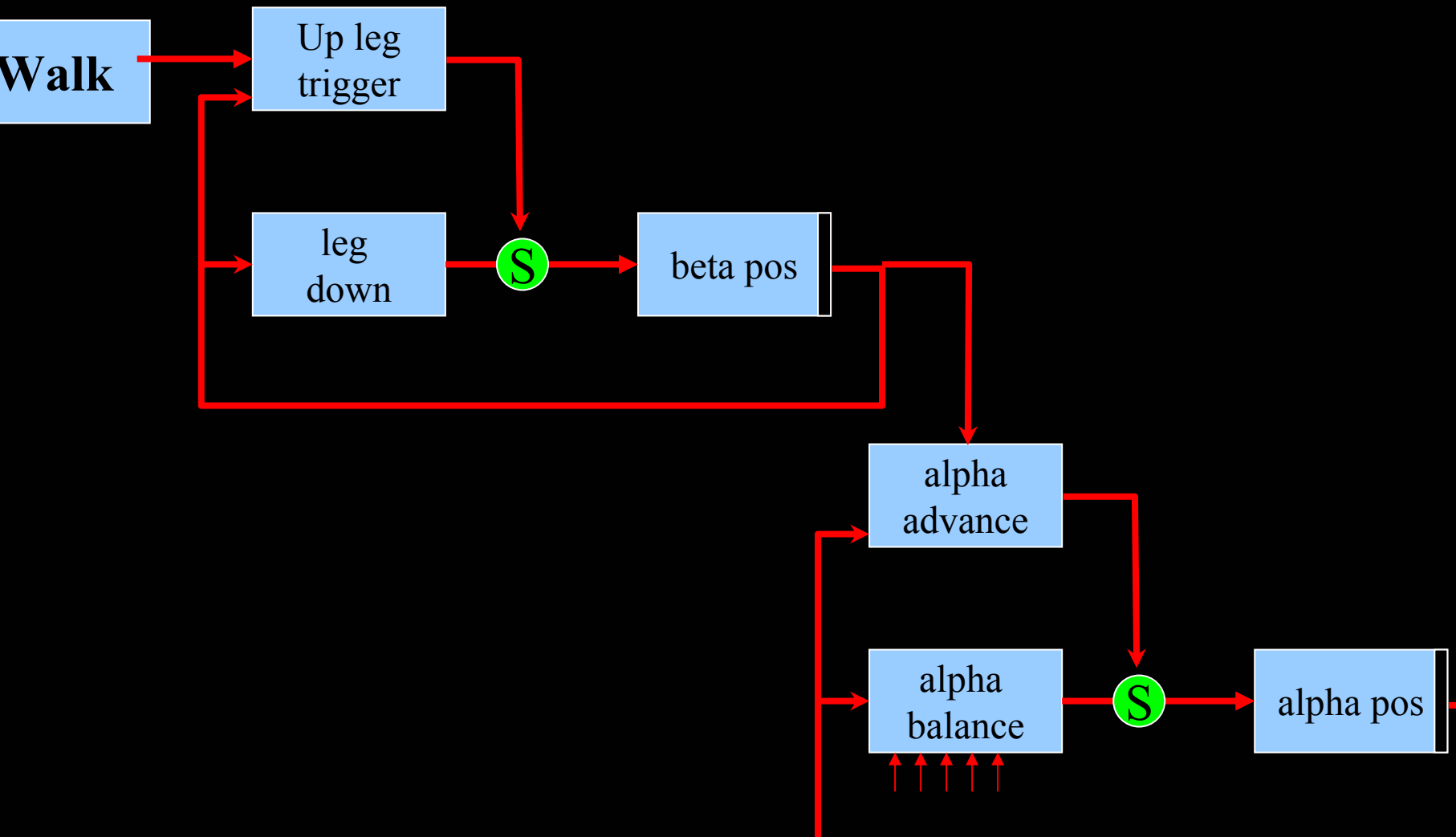

# Walking in rough terrain

